

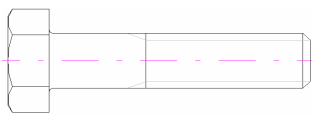



Norma / Standard / Norm			DIN 931 EN ISO 4014 STN 02 1101		
Presná skrutka so šesťhrannou hlavou Hexagon Head Bolts Sechskantschrauben Mechanické vlastnosti / Mechanical Properties / Mechanische Eigenschaften 5.6 , 5.8 , 6.8 , 8.8 , 10.9 Povrchová úprava / Surface Treatment / Oberflächenbehandlung A3F , A3G					
					
Rozmer / dimension / Ausmaß					
[d]	[l] min	[l] max	[d]	[l] min	[l] max
M5	25	50	M14	50	100
M6	30	80	M16	50	100
M8	35	100			
M10	40	100			
M12	45	100			

Norma / Standard / Norm			DIN 933 EN ISO 4017 STN 02 1103		
Presná skrutka so šesťhrannou hlavou Hexagon Head Bolts Sechskantschrauben Mechanické vlastnosti / Mechanical Properties / Mechanische Eigenschaften 5.6 , 5.8 , 6.8 , 8.8 , 10.9 Povrchová úprava / Surface Treatment / Oberflächenbehandlung A3F , A3G					
					
Rozmer / dimension / Ausmaß					
[d]	[l] min	[l] max	[d]	[l] min	[l] max
M3	-	-	M10	16	120
M4	-	-	M12	16	120
M5	6	50	M14	25	120
M6	8	60	M16	25	120
M8	10	120			

Norma / Standard / Norm			DIN 601 EN ISO 4016 STN 02 1301		
Hrubá skrutka so šesťhrannou hlavou Hexagon Head Bolts Sechskantschrauben mit Schaft, Produktklasse C, roh Mechanické vlastnosti / Mechanical Properties / Mechanische Eigenschaften 4.6 , 4.8 , 5.8 Povrchová úprava / Surface Treatment / Oberflächenbehandlung A3F , A3G					
					
Rozmer / dimension / Ausmaß					
[d]	[l] min	[l] max	[d]	[l] min	[l] max
M5	25	60	M16	50	120
M6	30	80			
M8	35	120			
M10	40	120			
M12	45	120			

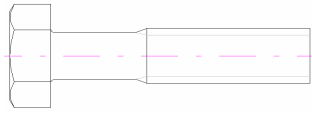
Norma / Standard / Norm			DIN 558 EN ISO 4018 STN 02 1303		
Hrubá skrutka so šesťhrannou hlavou Hexagon Head Bolts Sechskantschrauben mit Gewinde bis Kopf, Produktklasse C, roh Mechanické vlastnosti / Mechanical Properties / Mechanische Eigenschaften 4.6 , 4.8 , 5.8 Povrchová úprava / Surface Treatment / Oberflächenbehandlung A3F , A3G					
					
Rozmer / dimension / Ausmaß					
[d]	[l] min	[l] max	[d]	[l] min	[l] max
M5	6	60	M16	25	120
M6	8	70	M20	30	100
M8	10	120			
M10	16	120			
M12	16	120			

Norma / Standard / Norm			DIN 84	EN ISO 1207	STN 02 1131
Skrutky s valcovou hlavou Slotted cheese head screws Zylinderschrauben mit Schlitz					
Mechanické vlastnosti / Mechanical Properties / Mechanische Eigenschaften 5.8					
Povrchová úprava / Surface Treatment / Oberflächenbehandlung A3F , A3G					
Rozmer / dimension / Ausmaß					
[d]	[l] min	[l] max	[d]	[l] min	[l] max
M3	4	35	M8	12	80
M3,5	7	35			
M4	5	60			
M5	8	60			
M6	8	60			

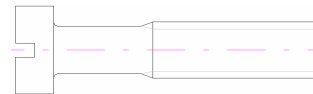

Norma / Standard / Norm			DIN 85	EN ISO 1580	STN 02 1137
Skrutky s veľkou valcovou hlavou Slotted pan head screws Flachkopfschrauben mit Schlitz					
Mechanické vlastnosti / Mechanical Properties / Mechanische Eigenschaften 5.8					
Povrchová úprava / Surface Treatment / Oberflächenbehandlung A3F , A3G					
Rozmer / dimension / Ausmaß					
[d]	[l] min	[l] max	[d]	[l] min	[l] max
M3	6	30	M8	10	60
M3,5	6	35			
M4	6	50			
M5	8	60			
M6	10	60			

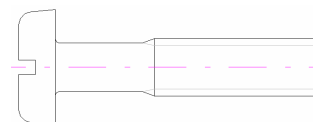

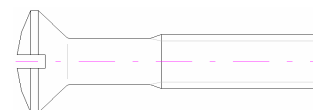

Norma / Standard / Norm			DIN 964	EN ISO 2010	STN 02 1155
Zápustné skrutky so šošovkovitou hlavou Slotted raised countersunk head screws Linsensenschrauben mit Schlitz					
Mechanické vlastnosti / Mechanical Properties / Mechanische Eigenschaften 5.8					
Povrchová úprava / Surface Treatment / Oberflächenbehandlung A3F , A3G					
Rozmer / dimension / Ausmaß					
[d]	[l] min	[l] max	[d]	[l] min	[l] max
M3	6	30			
M4	6	40			
M5	8	55			
M6	10	50			
M8	14	50			



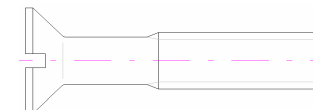

Norma / Standard / Norm			DIN 963	EN ISO 2009	STN 02 1151
Zápustné skrutky Slotted countersunk head screws Senkschrauben mit Schlitz					
Mechanické vlastnosti / Mechanical Properties / Mechanische Eigenschaften 5.8					
Povrchová úprava / Surface Treatment / Oberflächenbehandlung A3F , A3G					
Rozmer / dimension / Ausmaß					
[d]	[l] min	[l] max	[d]	[l] min	[l] max
M3	6	30			
M4	6	50			
M5	8	60			
M6	10	60			
M8	12	80			



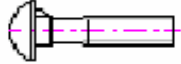

Norma / Standard / Norm			DIN 965	EN ISO 7046	STN 02 1152
Zápustná skrutka s krížovou drážkou					
Cross recessed countersunk head screws					
Senkschrauben mit Kreuzschlitz					
Mechanické vlastnosti / Mechanical Properties / Mechanische Eigenschaften					
5.8					
Povrchová úprava / Surface Treatment / Oberflächenbehandlung					
A3F , A3G					
Rozmer / dimension / Ausmaß					
[d]	[l] min	[l] max	[d]	[l] min	[l] max
M3	6	30			
M4	6	50			
M5	8	60			
M6	10	60			
M8	16	80			

Norma / Standard / Norm			DIN 966	EN ISO 7047	STN 02 1156
Zápustná skrutka so šošovkovitou hlavou a s krížovou drážkou					
Cross recessed raised countersunk head screws					
Linsensenkschrauben mit Kreuzschlitz					
Mechanické vlastnosti / Mechanical Properties / Mechanische Eigenschaften					
5.8					
Povrchová úprava / Surface Treatment / Oberflächenbehandlung					
A3F , A3G					
Rozmer / dimension / Ausmaß					
[d]	[l] min	[l] max	[d]	[l] min	[l] max
M3	6	30			
M4	6	50			
M5	8	50			
M6	10	55			
M8	16	50			

Norma / Standard / Norm			DIN 607	EN ISO	STN 02 1315
Skrutky s polgúľatou hlavou a s nosom					
Mushroom head nib bolts					
Halbrundsrauben mit Nase					
Mechanické vlastnosti / Mechanical Properties / Mechanische Eigenschaften					
4.6 , 8.8					
Povrchová úprava / Surface Treatment / Oberflächenbehandlung					
A3F , A3G					
Rozmer / dimension / Ausmaß					
[d]	[l] min	[l] max	[d]	[l] min	[l] max
M8	20	110			
M10	25	110			
M12	30	120			
M16	35	120			

Norma / Standard / Norm			DIN 603	EN ISO 8677	STN 02 1319
Skrutky s plochou guľatou hlavou a s nosom					
Mushroom head square neck bolts					
Flachrundsrauben mit Vierkantansatz					
Mechanické vlastnosti / Mechanical Properties / Mechanische Eigenschaften					
3.6 , 4.6					
Povrchová úprava / Surface Treatment / Oberflächenbehandlung					
A3F , A3G					
Rozmer / dimension / Ausmaß					
[d]	[l] min	[l] max	[d]	[l] min	[l] max
M5	16	80	M16	50	180
M6	16	100			
M8	20	180			
M10	20	180			
M12	30	180			

Norma / Standard / Norm			DIN 604	EN ISO	STN 02 1324
Zápustné skrutky s nosom					
Flat countersunk nib bolts					
Senkschrauben mit Nase					
Mechanické vlastnosti / Mechanical Properties / Mechanische Eigenschaften					
4.6					
Povrchová úprava / Surface Treatment / Oberflächenbehandlung					
A3F , A3G					
Rozmer / dimension / Ausmaß					
[d]	[l] min	[l] max	[d]	[l] min	[l] max
M8	20	100	M16	30	120
M6	20	60			
M10	20	100			
M12	30	120			

Norma / Standard / Norm			DIN 608	EN ISO	STN 02 1326
Zápustné skrutky so štvorhranom do kovu					
Flat countersunk square neck bolts with short square					
Senkschrauben mit niedrigen Vierkantansatz					
Mechanické vlastnosti / Mechanical Properties / Mechanische Eigenschaften					
4.6					
Povrchová úprava / Surface Treatment / Oberflächenbehandlung					
A3F , A3G					
Rozmer / dimension / Ausmaß					
[d]	[l] min	[l] max	[d]	[l] min	[l] max
M10	25	60			
M12	30	80			

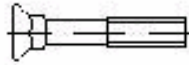
Norma / Standard / Norm			DIN 605	EN ISO	STN 02 1327
Zápustné skrutky so štvorhranom do dreva					
Flat coentersunk square neck bolts with long square					
Senkschrauben mit hohem Vierkantansatz					
Mechanické vlastnosti / Mechanical Properties / Mechanische Eigenschaften					
3.6 , 4.6					
Povrchová úprava / Surface Treatment / Oberflächenbehandlung					
A3F , A3G					
Rozmer / dimension / Ausmaß					
[d]	[l] min	[l] max	[d]	[l] min	[l] max
M5	30	70			
M6	30	80			
M8	30	80			
M10	40	100			

Norma / Standard / Norm			DIN 261	EN ISO	STN 02 1341
Skrutky s hlavou T					
T-head bolts with square neck					
Hammerschrauben mit Vierkant					
Mechanické vlastnosti / Mechanical Properties / Mechanische Eigenschaften					
3.6 , 4.6					
Povrchová úprava / Surface Treatment / Oberflächenbehandlung					
A3F , A3G					
Rozmer / dimension / Ausmaß					
[d]	[l] min	[l] max	[d]	[l] min	[l] max
M12	45	100			

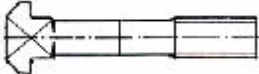
Norma / Standard / Norm			DIN 186	EN ISO	STN 02 1343
Skrutka s hlavou T a so štvorhranom T-head bolts with square neck Hammerschrauben mit Vierkant Mechanické vlastnosti / Mechanical Properties / Mechanische Eigenschaften 3.6 , 4.6 Povrchová úprava / Surface Treatment / Oberflächenbehandlung A3F , A3G					
Rozmer / dimension / Ausmaß					
[d]	[l] min	[l] max	[d]	[l] min	[l] max
M10	40	90			
M12	45	110			

Norma / Standard / Norm			DIN 7985	EN ISO 7045	STN 02 1138
Skrutky s polgulfatou hlavou a krížovou drážkou do kovu Cross recessed pan head screws Halbrundschrauben mit Kreuzschlitz Mechanické vlastnosti / Mechanical Properties / Mechanische Eigenschaften 4.8 , 5.8 Povrchová úprava / Surface Treatment / Oberflächenbehandlung A3F , A3G					
Rozmer / dimension / Ausmaß					
[d]	[l] min	[l] max	[d]	[l] min	[l] max
M3	6	30			
M4	8	30			
M5	10	50			
M6	10	60			

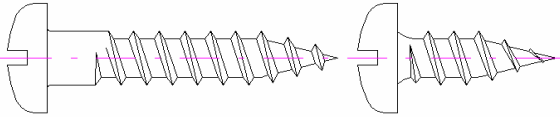
Norma / Standard / Norm			DIN 96	EN ISO	STN 02 1812
Skrutky do dreva s polgulfatou hlavou Slotted round head wood screws Halbrundholzschrauben mit Schlitz Materiál / Material / Material ocel/steel/stahl mosadz/brass/messing Povrchová úprava / Surface Treatment / Oberflächenbehandlung A3F , A3G					
Rozmer / dimension / Ausmaß					
[d]	[l] min	[l] max	[d]	[l] min	[l] max
1,6	8	12	4	12	60
2	8	20	5	12	70
2,5	8	30	6	20	100
3	10	40	8	40	100
3,5	10	40			

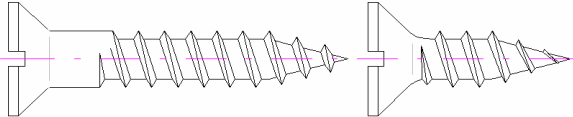
Norma / Standard / Norm			DIN 97	EN ISO	STN 02 1814
Skrutky do dreva so zapustenou hlavou Slotted countersunk head wood screws Senkholzschrauben mit Schlitz Materiál / Material / Material ocel/steel/stahl mosadz/brass/messing Povrchová úprava / Surface Treatment / Oberflächenbehandlung A3F , A3G					
Rozmer / dimension / Ausmaß					
[d]	[l] min	[l] max	[d]	[l] min	[l] max
1,6	8	12	4	12	70
2	8	20	5	12	90
2,5	8	30	6	20	100
3	10	40	8	40	100
3,5	10	50			

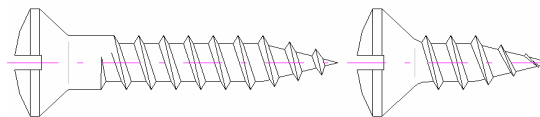
Norma / Standard / Norm			DIN 95	EN ISO	STN 02 1815
Skrutky do dreva so zapustenou šošovkovitou hlavou Slotted raised countersunk head wood screws Linsensenkholzschrauben mit Schlitz					
Materiál / Material / Material					
ocel/steel/stahl mosadz/brass/messing					
Povrchová úprava / Surface Treatment / Oberflächenbehandlung					
A3F , A3G					
Rozmer / dimension / Ausmaß					
[d]	[l] min	[l] max	[d]	[l] min	[l] max
2	8	20	5	12	70
2,5	8	30	6	20	100
3	10	35			
3,5	10	40			
4	12	60			

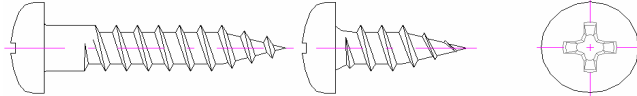
Norma / Standard / Norm			DIN 7996	EN ISO	STN 02 1822
Skrutky do dreva s polguľatou hlavou a s krížovou drážkou Slotted round head wood screws Halbrundholzschrauben mit Kreuzschlitz					
Materiál / Material / Material					
ocel/steel/stahl mosadz/brass/messing					
Povrchová úprava / Surface Treatment / Oberflächenbehandlung					
A3F , A3G					
Rozmer / dimension / Ausmaß					
[d]	[l] min	[l] max	[d]	[l] min	[l] max
2,5	8	30	6	20	80
3	10	30	8	40	80
3,5	10	40			
4	12	60			
5	12	70			

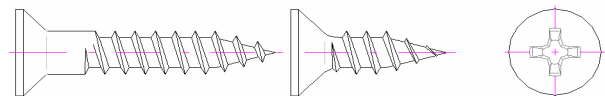
Norma / Standard / Norm			DIN 7997	EN ISO	STN 02 1824
Skrutky do dreva so zapustenou hlavou a krížovou drážkou Slotted countersunk head wood screws Senkholzschrauben mit Kreuzschlitz					
Materiál / Material / Material					
ocel/steel/stahl mosadz/brass/messing					
Povrchová úprava / Surface Treatment / Oberflächenbehandlung					
A3F , A3G					
Rozmer / dimension / Ausmaß					
[d]	[l] min	[l] max	[d]	[l] min	[l] max
2,5	8	30	6	20	100
3	10	40	8	40	120
3,5	10	40			
4	12	60			
5	12	70			

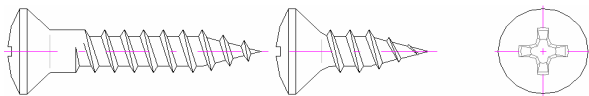
Norma / Standard / Norm			DIN 7995	EN ISO	STN 02 1816
Skrutky do dreva so zapustenou šošovkovitou hlavou a s krížovou drážkou Slotted raised countersunk head wood screws Linsensenkholzschrauben mit Kreuzschlitz					
Materiál / Material / Material					
ocel/steel/stahl mosadz/brass/messing					
Povrchová úprava / Surface Treatment / Oberflächenbehandlung					
A3F , A3G					
Rozmer / dimension / Ausmaß					
[d]	[l] min	[l] max	[d]	[l] min	[l] max
2,5	8	30	6	25	80
3	10	30	8	60	80
3,5	10	40			
4	12	60			
5	12	70			

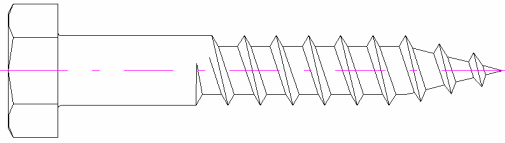
Norma / Standard / Norm			DIN 571	EN ISO	STN 02 1810
Skrutky do dreva so šesťhrannou hlavou Hexagon head wood screws Sechskantholzschrauben					
Materiál / Material / Material ocel/steel/stahl mosadz/brass/messing					
Povrchová úprava / Surface Treatment / Oberflächenbehandlung A3F , A3G					
Rozmer / dimension / Ausmaß					
[d]	[l] min	[l] max	[d]	[l] min	[l] max
5	20	70			
6	25	120			
8	30	120			
10	40	120			

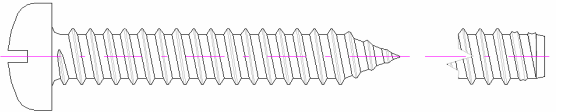
Norma / Standard / Norm			DIN 7971	EN ISO 1481	STN 02 1232
Skrutky do plechu s valcovou hlavou Slotted pan head tapping screws Blehschrauben mit Schlitz a Zylinderkopf					
Materiál / Material / Material ocel/steel/stahl					
Povrchová úprava / Surface Treatment / Oberflächenbehandlung A3F , A3G					
Rozmer / dimension / Ausmaß					
[d]	[l] min	[l] max	[d]	[l] min	[l] max
2,9	9,5	19	5,5	16	38
3,5	9,5	25	6,3	16	38
3,9	9,5	25			
4,2	13	32			
4,8	13	32			

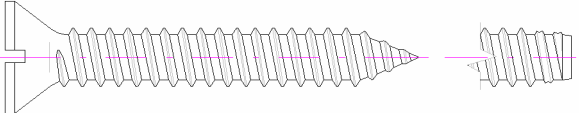
Norma / Standard / Norm			DIN 7972	EN ISO 1482	STN 02 1236
Skrutky do plechu so zápustnou hlavou Tapping screws with slot Blehschrauben mit Schlitz und Senkkopf					
Materiál / Material / Material ocel/steel/stahl					
Povrchová úprava / Surface Treatment / Oberflächenbehandlung A3F , A3G					
Rozmer / dimension / Ausmaß					
[d]	[l] min	[l] max	[d]	[l] min	[l] max
2,9	6,5	19	5,5	16	38
3,5	9,5	25	6,3	16	38
3,9	9,5	25			
4,2	13	32			
4,8	13	32			

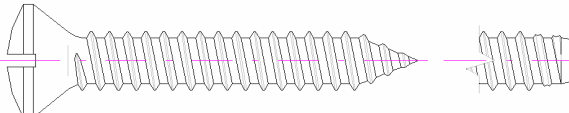
Norma / Standard / Norm			DIN 7973	EN ISO 1483	STN 02 1238
Skrutky do plechu so zápustnou šošovkovitou hlavou Tapping screws with slot Blehschrauben mit Schlitz und Linsensenkkopf					
Materiál / Material / Material ocel/steel/stahl					
Povrchová úprava / Surface Treatment / Oberflächenbehandlung A3F , A3G					
Rozmer / dimension / Ausmaß					
[d]	[l] min	[l] max	[d]	[l] min	[l] max
2,9	6,5	19	5,5	16	38
3,5	9,5	25	6,3	16	38
3,9	9,5	25			
4,2	13	32			
4,8	13	32			

Norma / Standard / Norm			DIN 7976	EN ISO 1479	STN 02 1231
Skrutky do plechu so šest'hrannou hlavou Hexagon head tapping screws Blechschauben mit Sechskantkopf					
Materiál / Material / Material ocel/steel/stahl					
Povrchová úprava / Surface Treatment / Oberflächenbehandlung A3F , A3G					
Rozmer / dimension / Ausmaß					
[d]	[l] min	[l] max	[d]	[l] min	[l] max
2,9	6,5	19	5,5	16	50
3,5	9,5	25	6,3	19	50
3,9	13	25			
4,2	13	32			
4,8	13	50			

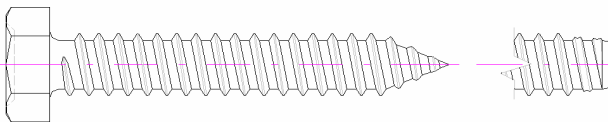

Norma / Standard / Norm			DIN 7981	EN ISO 7049	STN 02 1235
Skrutky do plechu s valcovou hlavou Cross recessed pan head tapping screws Blechschauben mit Kreuzschlitz und Linsenkopf					
Materiál / Material / Material ocel/steel/stahl					
Povrchová úprava / Surface Treatment / Oberflächenbehandlung A3F , A3G					
Rozmer / dimension / Ausmaß					
[d]	[l] min	[l] max	[d]	[l] min	[l] max
2,9	6,5	19	5,5	16	38
3,5	9,5	25	6,3	16	38
3,9	9,5	25			
4,2	13	32			
4,8	13	32			

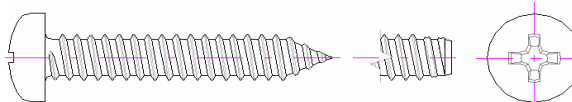

Norma / Standard / Norm			DIN 7982	EN ISO 7050	STN 02 1237
Skrutky do plechu so zápustnou hlavou Tapping screws with cross recessed Blechschauben mit Kreuzschlitz und Senkkopf					
Materiál / Material / Material ocel/steel/stahl					
Povrchová úprava / Surface Treatment / Oberflächenbehandlung A3F , A3G					
Rozmer / dimension / Ausmaß					
[d]	[l] min	[l] max	[d]	[l] min	[l] max
2,9	6,5	19	5,5	16	38
3,5	9,5	25	6,3	16	38
3,9	9,5	25			
4,2	13	32			
4,8	13	32			

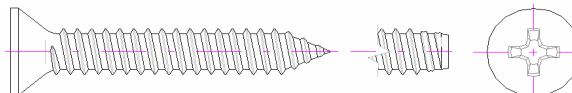

Norma / Standard / Norm			DIN 7983	EN ISO 7051	STN 02 1239
Skrutky do plechu so zápustnou šoškovkovitou hlavou Tapping screws with cross recessed Blechschauben mit Kreuzschlitz und Linsensenkkopf					
Materiál / Material / Material ocel/steel/stahl					
Povrchová úprava / Surface Treatment / Oberflächenbehandlung A3F , A3G					
Rozmer / dimension / Ausmaß					
[d]	[l] min	[l] max	[d]	[l] min	[l] max
2,9	6,5	19	5,5	16	38
3,5	9,5	25	6,3	16	38
3,9	9,5	25			
4,2	13	32			
4,8	13	32			

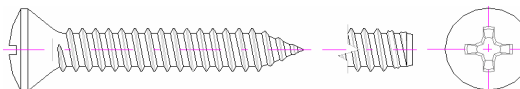

Norma / Standard / Norm			DIN 124/660	EN ISO	STN 02 2301
Nity plné s polgufatou hlavou Round head rivets Halbrundniete					
Materiál / Material / Material ocel/steel/stahl mosadz/brass/messing hliník/aluminium					
Povrchová úprava / Surface Treatment / Oberflächenbehandlung A3F , A3G					
Rozmer / dimension / Ausmaß					
[d]	[l] min	[l] max	[d]	[l] min	[l] max
2	4	20	5,6,8	8	70
2,5	4	24	10	14	110
3	4	40	12	16	130
3,5	6	40	14	20	95
4	6	45	16	24	110

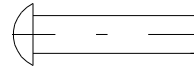

Norma / Standard / Norm			DIN 661	EN ISO	STN 02 2311
Zápustné nity plné Countersunk head rivets Senkniete					
Materiál / Material / Material ocel/steel/stahl mosadz/brass/messing hliník/aluminium					
Povrchová úprava / Surface Treatment / Oberflächenbehandlung A3F , A3G					
Rozmer / dimension / Ausmaß					
[d]	[l] min	[l] max	[d]	[l] min	[l] max
2	6	20	8	10	80
2,5	6	24	10	16	110
3	6	40	12	16	85
3,5;4	6	45	14	20	95
5,6,8	8	60	16	24	110

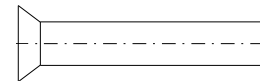

Norma / Standard / Norm			DIN 7338	EN ISO	STN 02 2330
Nity plné s plochou hlavou Flat head rivets Flachkopfnieten					
Materiál / Material / Material ocel/steel/stahl mosadz/brass/messing hliník/aluminium					
Povrchová úprava / Surface Treatment / Oberflächenbehandlung A3F , A3G					
Rozmer / dimension / Ausmaß					
[d]	[l] min	[l] max	[d]	[l] min	[l] max
2,5	6	25	8	10	60
3	6	40			
4	8	40			
5	8	60			
6	8	60			

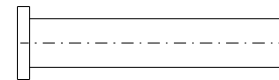

Výkres / Drawing / Zeichnung				SL 4075	
Skrutka Screws Schraube					
Mechanické vlastnosti / Mechanical Properties / Mechanische Eigenschaften 8. 8					
Povrchová úprava / Surface Treatment / Oberflächenbehandlung A3F , A3G					
Rozmer / dimension / Ausmaß					
[d]	[l] min	[l] max	[d]	[l] min	[l] max
M12	35	50			

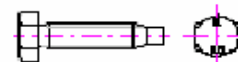

Skrutka s podložkou

Screws

Schraube mit Unterlegscheibe

Mechanické vlastnosti / Mechanical Properties / Mechanische Eigenschaften

5. 8

Povrchová úprava / Surface Treatment / Oberflächenbehandlung

A3F , A3G



Rozmer / dimension / Ausmaß

[d]	[l] min	[l] max	[d]	[l] min	[l] max
M3	6	20			
M4	6	40			
M5	8	45			
M6	8	50			